

Guardian™ Roll-Up Safety Barrier

HEAVY DUTY, MOTOR DRIVEN SAFETY BARRIER

BARRIER CURTAIN

Provides safety from weld flash, flying debris and entry into work area

HIGH CYCLES AND HIGH SPEED

30" per second operation helps improve productivity

PROVEN DESIGN

Reduces downtime and maintenance costs

SOFT BOTTOM EDGE

Protects personnel and property from impact damage

SAFETY INTERLOCK SWITCHES

Provide safety and automate process

MACHINE GUARDING PRODUCTS



INCREASE PRODUCTIVITY AND SAFETY WITH THE GUARDIAN BARRIER CURTAIN

Get the Guardian from Frommelt® Safety Products for robotic work cells, conveyor openings and all machine guarding areas. Protect your employees from weld flash, flying debris and entry into hazardous work areas.

This unique product combines the benefits of light curtains, safety mats, and fencing into one product for half the price.

The Guardian is ideal for customers interested in improving safety and reducing maintenance downtime.

For more details, contact us at 800-553-5560.

**Guardian™**
Roll-Up Barrier

 **Frommelt®**
SAFETY PRODUCTS
Integrating Fabrics With Technology



Guardian™

Roll-Up Barrier

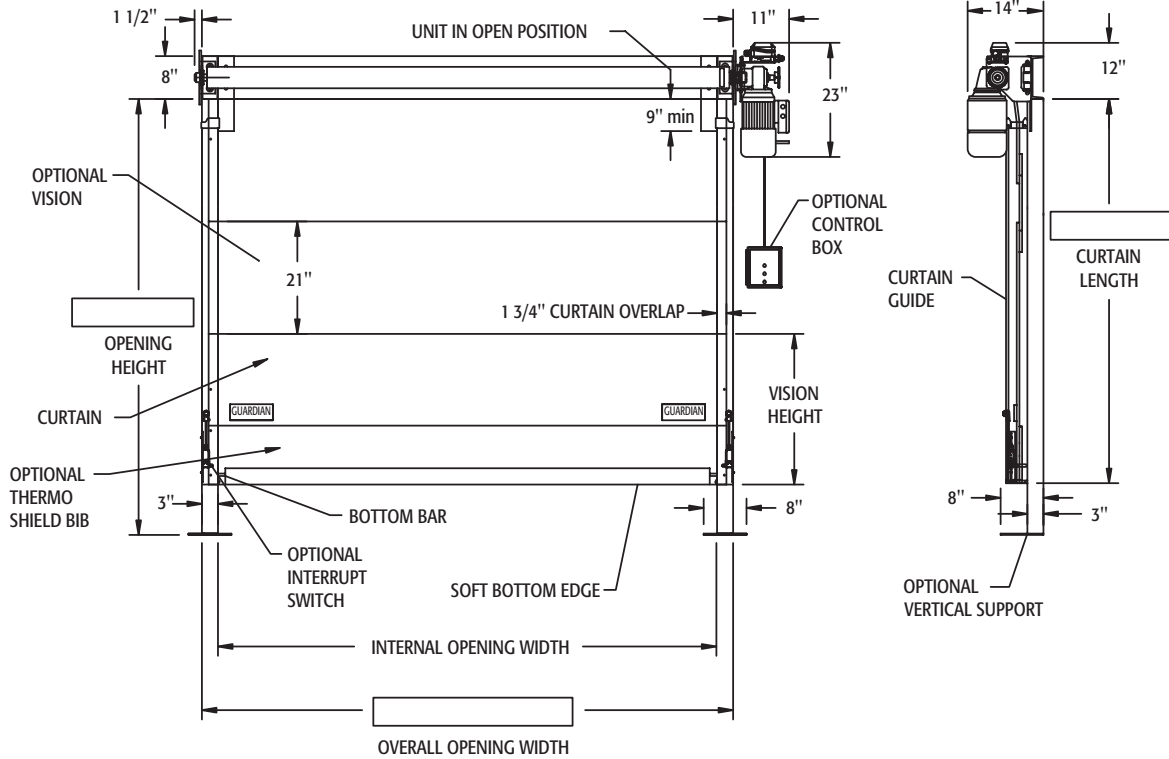
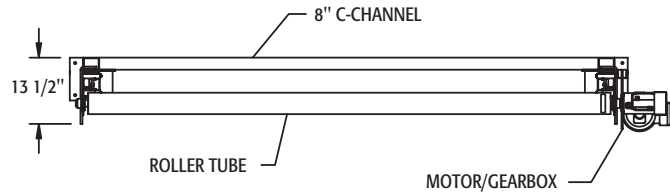

SPECIFICATIONS:

- MODEL NUMBER:** 1340 Guardian™ Barrier
- SIZE:** Minimum: 2'-2"W x 8'-0"H
Maximum: 12'-6"W x 12'-0"H
- SPEED:** 30" per second operation
- CURTAIN MATERIAL:** Standard 50 oz. black Armorpleat™ with optional 21" high, full-width vision panel
- ROLLER TUBE:** 4" diameter steel tube
- CURTAIN GUIDES:** 14 gauge steel
- HEADER MATERIAL:** 8" x 2" x 11-1/2 lbs. c-channel
- MOTOR:** 3 phase, 1 H.P. motor with brake
- GEAR BOX:** Worm gear reducer, 15:1 ratio
- CONTROL BOX:** Optional: PLC style, Size: 16" x 14" x 8"
Optional: Standard non PLC style, Size: 12" x 10" x 6"
- SAFETY FEATURES:** Soft bottom edge design protects personnel and property, optional safety interlock switch
- WARRANTY:** Limited 1-year parts

CUSTOMER

END USER

SIZE

QUANTITY

CUSTOMER APPROVAL

SIGNATURE

DATE



4343 Chavenelle Drive
Dubuque, Iowa 52002-2654
Toll Free: 800-553-5560
1-563-587-4401
Fax: 563-589-2776
www.frommelt.com



Printed in USA
©2003 Frommelt Safety Products